







Reducers for Ex d/e Applications

Technical Details		
Material	Body	Brass, Brass Nickel Plated, Stainless Steel 316L
	O-Ring	CR (Chloroprene), Silicone
Ingress Protection Rating	IP 68 - 5 Bar, 30 min IP 66	
Operating Temperature	O-ring Material	
	CR (Chloroprene)	Silicone
Ex d/e/tb	-40°C to +100°C -60°C to +130°C	
Equipment For	• Gas & Dust potentially explosive atmospheres.	
Suitable for use in	Group II	Gas Group IIC ZONE1/ZONE2
	Group III	Dust Group IIIC ZONE21/ZONE 22
Equipment Marking	Ex II 2GD Ex db IIC Gb Ex eb IIC Gb Ex tb IIIC Db	
Marking Example *	BMD B-RA.. CE 0722  II 2GD Ex db IIC Gb Ex eb IIC Gb Ex tb IIIC Db Tq-40°C to +100°C IP66/68 CESI 13 ATEX 066X IECEx CES 13.0022X	
Thread Type	<ul style="list-style-type: none"> • Metric (M) ISO Pitch 1,5 • Npt (N) ANSI ASME B1.20.1 • PG (P) DIN 40430 • (G) GAS UNI ISO 228/1 	
Accessories	• Gaskets (Washers)	
Remarks	<ul style="list-style-type: none"> • Accessories must be ordered separately. • O-ring available in Metric. 	
Approvals	Certificate Number	Standards
	CESI 13 ATEX 066X	EN 60079-0:2012+A11:2013 EN 60079-1:2014 EN 60079-7:2015 EN 60079-31:2014
	IECEx CES 13.0022X	IEC 60079-0:2011 Edition:6 IEC 60079-1:2014 Edition:7 IEC 60079-31:2013 Edition:2 IEC 60079-7:2015 Edition:5
	№ TC RU C-TR.AA87.B.00941	ГОСТ 31610.0-2014 ГОСТ IEC 60079-1:2013 ГОСТ IEC 60079-31:2013
	DNV 12.0150 X	ABNT NBR IEC 60079-0:2008, ABNT NBR IEC 60079-1:2009, ABNT NBR IEC 60079-7:2008, ABNT NBR IEC 60079-31:2011
	E-14044	IEC/EN60079-0, IEC/EN60079-7, IEC/EN60079-31, IEC/EN60079-1 & IEC/EN 62444

- Other sizes available upon request. For more information see our webpage.
* The standard marking consists ATEX & IECEx only. Marking acc. to other standards on request.

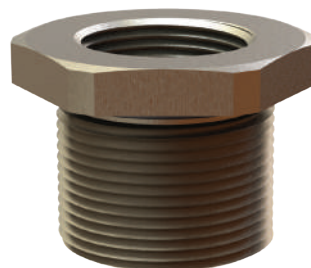
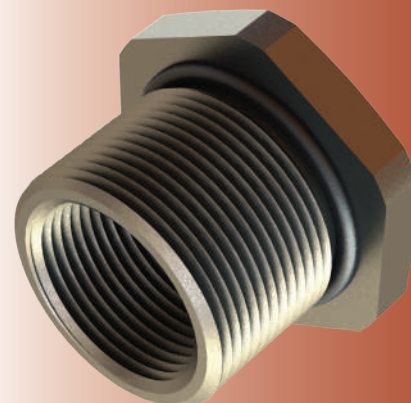

Order Coding				
Part Number	Material	Seal	Gasket (Washer)	
	Mandatory	Mandatory	-	Option
See table	B Brass BN Brass Nickel plated X Stainless steel 316L	C Chloroprene S Silicone	-	WC Chloroprene WS Silicone WF Fiber
Example				
B-RA2M01M	BN	C	-	WS

GRUS

Reducers for Ex d/e Applications

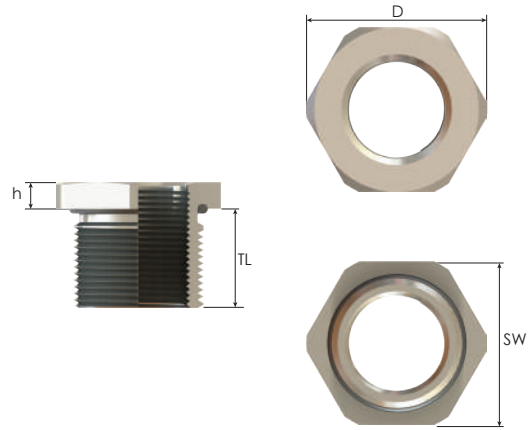

Thread Type METRIC > METRIC acc. to ISO965-3						
Outer Thread Size (Male)	Inner Thread Size (Female)	Outer Thread Length	Spanner Width	Outer Ø	Height	Part Number
		TL mm	SW mm	D mm	h mm	
M20x1,5	M16x1,5	15,0	25	27,5	4,0	B-RA1M01M
M25x1,5	M16x1,5	15,0	30	33,0	4,0	B-RA2M01M
	M20x1,5	15,0	30	33,0	4,0	B-RA2M1M
M32x1,5	M16x1,5	15,0	36	39,5	4,0	B-RA3M01M
	M20x1,5	15,0	36	39,5	4,0	B-RA3M1M
	M25x1,5	15,0	36	39,5	4,0	B-RA3M2M
M40x1,5	M16x1,5	18,0	45	50,0	4,0	B-RA4M01M
	M20x1,5	18,0	45	50,0	4,0	B-RA4M1M
	M25x1,5	18,0	45	50,0	4,0	B-RA4M2M
	M32x1,5	18,0	45	50,0	4,0	B-RA4M3M
M50x1,5	M16x1,5	18,0	55	61,0	5,0	B-RA5M01M
	M20x1,5	18,0	55	61,0	5,0	B-RA5M1M
	M25x1,5	18,0	55	61,0	5,0	B-RA5M2M
	M32x1,5	18,0	55	61,0	5,0	B-RA5M3M
	M40x1,5	18,0	55	61,0	5,0	B-RA5M4M
M60x1,5	M20x1,5	18,0	70	77,0	5,0	B-RA6M1M
	M25x1,5	18,0	70	77,0	5,0	B-RA6M2M
	M32x1,5	18,0	70	77,0	5,0	B-RA6M3M
	M40x1,5	18,0	70	77,0	5,0	B-RA6M4M
	M50x1,5	18,0	70	77,0	5,0	B-RA6M5M
M63x1,5	M20x1,5	18,0	70	77,0	5,0	B-RA6M1M
	M25x1,5	18,0	70	77,0	5,0	B-RA6M2M
	M32x1,5	18,0	70	77,0	5,0	B-RA6M3M
	M40x1,5	18,0	70	77,0	5,0	B-RA6M4M
	M50x1,5	18,0	70	77,0	5,0	B-RA6M5M
M70x1,5	M25x1,5	18,0	80	89,0	6,0	B-RA7M2M
	M32x1,5	18,0	80	89,0	6,0	B-RA7M3M
	M40x1,5	18,0	80	89,0	6,0	B-RA7M4M
	M50x1,5	18,0	80	89,0	6,0	B-RA7M5M
	M60x1,5	18,0	80	89,0	6,0	B-RA7M60M
M75x1,5	M32x1,5	18,0	85	94,0	6,0	B-RA7M3M
	M40x1,5	18,0	85	94,0	6,0	B-RA7M4M
	M50x1,5	18,0	85	94,0	6,0	B-RA7M5M
	M60x1,5	18,0	85	94,0	6,0	B-RA7M60M
	M63x1,5	18,0	85	94,0	6,0	B-RA7M6M
M80x1,5	M40x1,5	18,0	90	100,0	6,0	B-RA8M4M
	M50x1,5	18,0	90	100,0	6,0	B-RA8M5M
	M60x1,5	18,0	90	100,0	6,0	B-RA8M60M
	M63x1,5	18,0	90	100,0	6,0	B-RA8M6M
	M70x1,5	18,0	90	100,0	6,0	B-RA8M70M
M85x1,5	M50x1,5	21,0	95	105,0	8,0	B-RA85M5M
	M60x1,5	21,0	95	105,0	8,0	B-RA85M60M
	M63x1,5	21,0	95	105,0	8,0	B-RA85M6M
	M70x1,5	21,0	95	105,0	8,0	B-RA85M70M
	M75x1,5	21,0	95	105,0	8,0	B-RA85M7M
M90x1,5	M63x1,5	21,0	100	111,0	8,0	B-RA8M6M
	M70x1,5	21,0	100	111,0	8,0	B-RA8M70M
	M75x1,5	21,0	100	111,0	8,0	B-RA8M7M
	M80x1,5	21,0	100	111,0	8,0	B-RA8M80M
M100x1,5	M80x1,5	21,0	110	123,0	10,0	B-RA9M80M
	M85x1,5	21,0	110	123,0	10,0	B-RA9M85M
	M90x1,5	21,0	110	123,0	10,0	B-RA9M8M
M110x1,5	M90x1,5	21,0	120	133,5	10,0	B-RA10M8M
	M100x1,5	21,0	120	133,5	10,0	B-RA10M9M

GRUS Reducers for Ex d/e Applications

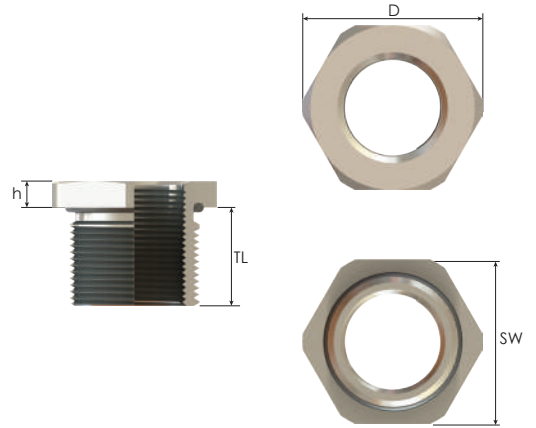

Thread Type **METRIC** acc. to ISO 965-3 > **NPT** acc. to ANSI ASME B1.20.1

Outer Thread Size (Male)	Inner Thread Size (Female)	Outer Thread Length	Spanner Width	Outer Ø	Height	Part Number
		TL mm	SW mm	D mm	h mm	
M20x1,5	NPT 3/8"	15,0	25	27,5	4,0	B-RA1M01N
	NPT 3/8"	15,0	30	33,0	4,0	B-RA2M01N
M25x1,5	NPT 1/2"	15,0	30	33,0	4,0	B-RA2M1N
	NPT 3/8"	15,0	36	39,5	4,0	B-RA3M01N
M32x1,5	NPT 1/2"	15,0	36	39,5	4,0	B-RA3M1N
	NPT 3/4"	15,0	36	39,5	4,0	B-RA3M2N
	NPT 3/8"	18,0	45	50,0	4,0	B-RA4M01N
M40x1,5	NPT 1/2"	18,0	45	50,0	4,0	B-RA4M1N
	NPT 3/4"	18,0	45	50,0	4,0	B-RA4M2N
	NPT 3/8"	18,0	55	61,0	5,0	B-RA5M01N
M50x1,5	NPT 1/2"	18,0	55	61,0	5,0	B-RA5M1N
	NPT 3/4"	18,0	55	61,0	5,0	B-RA5M2N
	NPT 3/8"	18,0	70	77,0	5,0	B-RA6M0M1N
M60x1,5	NPT 1/2"	18,0	70	77,0	5,0	B-RA6M0M1N
	NPT 3/4"	18,0	70	77,0	5,0	B-RA6M0M2N
	NPT 1"	18,0	70	77,0	5,0	B-RA6M0M3N
	NPT 3/8"	18,0	70	77,0	5,0	B-RA6M01N
M63x1,5	NPT 1/2"	18,0	70	77,0	5,0	B-RA6M1N
	NPT 3/4"	18,0	70	77,0	5,0	B-RA6M2N
	NPT 1"	18,0	70	77,0	5,0	B-RA6M3N
	NPT 3/8"	18,0	80	89,0	6,0	B-RA7M0M1N
M70x1,5	NPT 1/2"	18,0	80	89,0	6,0	B-RA7M0M1N
	NPT 3/4"	18,0	80	89,0	6,0	B-RA7M0M2N
	NPT 1"	18,0	80	89,0	6,0	B-RA7M0M3N
	NPT 1 1/4"	18,0	80	89,0	6,0	B-RA7M0M4N
	NPT 1/2"	18,0	80	89,0	6,0	B-RA7M1N
M75x1,5	NPT 3/4"	18,0	85	94,0	6,0	B-RA7M2N
	NPT 1"	18,0	85	94,0	6,0	B-RA7M3N
	NPT 1 1/4"	18,0	85	94,0	6,0	B-RA7M4N
	NPT 1 1/2"	18,0	85	94,0	6,0	B-RA7M5N
	NPT 3/4"	18,0	90	100,0	6,0	B-RA8M0M2N
M80x1,5	NPT 1"	18,0	90	100,0	6,0	B-RA8M0M3N
	NPT 1 1/4"	18,0	90	100,0	6,0	B-RA8M0M4N
	NPT 1 1/2"	18,0	90	100,0	6,0	B-RA8M0M5N
	NPT 2"	18,0	90	100,0	6,0	B-RA8M0M6N
	NPT 1"	21,0	95	105,0	8,0	B-RA8M3N
M85x1,5	NPT 1 1/4"	21,0	95	105,0	8,0	B-RA8M4N
	NPT 1 1/2"	21,0	95	105,0	8,0	B-RA8M5N
	NPT 2"	21,0	95	105,0	8,0	B-RA8M6N
	NPT 2 1/2"	21,0	95	105,0	8,0	B-RA8M7N
	NPT 1 1/4"	21,0	100	111,0	8,0	B-RA8M4N
M90x1,5	NPT 1 1/2"	21,0	100	111,0	8,0	B-RA8M5N
	NPT 2"	21,0	100	111,0	8,0	B-RA8M6N
	NPT 2 1/2"	21,0	100	111,0	8,0	B-RA8M7N
	NPT 1 1/2"	21,0	110	123,0	10,0	B-RA9M5N
M100x1,5	NPT 2"	21,0	110	123,0	10,0	B-RA9M6N
	NPT 2 1/2"	21,0	110	123,0	10,0	B-RA9M7N
	NPT 3"	21,0	110	123,0	10,0	B-RA9M8N
M110x1,5	NPT 2"	21,0	120	133,5	10,0	B-RA10M6N
	NPT 2 1/2"	21,0	120	133,5	10,0	B-RA10M7N

GRUS

Reducers for Ex d/e Applications

Thread Type **NPT** > **NPT** acc. to ANSI ASME B1.20.1

Outer Thread Size (Male)	Inner Thread Size (Female)	Outer Thread Length	Spanner Width	Outer Ø	Height	Part Number
		TL mm	SW mm	D mm	h mm	
NPT 1/2"	NPT 3/8"	15,0	25	27,5	4,0	B-RA1N01N
NPT 3/4"	NPT 3/8"	15,0	30	33	4,0	B-RA2N01N
	NPT 1/2"	15,0	30	33	4,0	B-RA2N1N
NPT 1"	NPT 3/8"	15,0	36	39,5	4,0	B-RA3N01N
	NPT 1/2"	15,0	36	39,5	4,0	B-RA3N1N
	NPT 3/4"	15,0	36	39,5	4,0	B-RA3N2N
NPT 1 1/4"	NPT 1/2"	18,0	45	50	4,0	B-RA4N1N
	NPT 3/4"	18,0	45	50	4,0	B-RA4N2N
	NPT 1"	18,0	45	50	4,0	B-RA4N3N
NPT 1 1/2"	NPT 3/4"	18,0	55	61	5,0	B-RA5N2N
	NPT 1"	18,0	55	61	5,0	B-RA5N3N
	NPT 1 1/4"	18,0	55	61	5,0	B-RA5N4N
NPT 2"	NPT 3/4"	18,0	65	72	5,0	B-RA6N2N
	NPT 1"	18,0	65	72	5,0	B-RA6N3N
	NPT 1 1/4"	18,0	65	72	5,0	B-RA6N4N
	NPT 1 1/2"	18,0	65	72	5,0	B-RA6N5N
NPT 2 1/2"	NPT 3/4"	28,0	75	83	6,0	B-RA7N2N
	NPT 1"	28,0	75	83	6,0	B-RA7N3N
	NPT 1 1/4"	28,0	75	83	6,0	B-RA7N4N
	NPT 1 1/2"	28,0	75	83	6,0	B-RA7N5N
	NPT 2"	28,0	75	83	6,0	B-RA7N6N
NPT 3"	NPT 1"	28,0	95	105	8,0	B-RA8N3N
	NPT 1 1/4"	28,0	95	105	8,0	B-RA8N4N
	NPT 1 1/2"	28,0	95	105	8,0	B-RA8N5N
	NPT 2"	28,0	95	105	8,0	B-RA8N6N
	NPT 2 1/2"	28,0	95	105	8,0	B-RA8N7N
NPT 3 1/2"	NPT 1 1/4"	28,0	110	123	10,0	B-RA9N4N
	NPT 1 1/2"	28,0	110	123	10,0	B-RA9N5N
	NPT 2"	28,0	110	123	10,0	B-RA9N6N
	NPT 2 1/2"	28,0	110	123	10,0	B-RA9N7N
	NPT 3"	28,0	110	123	10,0	B-RA9N8N
NPT 4"	NPT 1 1/2"	28,0	120	133,5	10,0	B-RA10N5N
	NPT 2"	28,0	120	133,5	10,0	B-RA10N6N
	NPT 2 1/2"	28,0	120	133,5	10,0	B-RA10N7N
	NPT 3"	28,0	120	133,5	10,0	B-RA10N8N

Thread Type **NPT** acc. to ANSI ASME B1.20.1 > **METRIC** acc. to ISO 965-3

Outer Thread Size (Male)	Inner Thread Size (Female)	Outer Thread Length	Spanner Width	Outer Ø	Height	Part Number
		TL mm	SW mm	D mm	h mm	
NPT 1/2"	M16x1,5	15,0	25	27,5	4,0	B-RA1N01M
NPT 3/4"	M16x1,5	15,0	30	33	4,0	B-RA2N01M
	M20x1,5	15,0	30	33	4,0	B-RA2N1M
NPT 1"	M16x1,5	15,0	36	39,5	4,0	B-RA3N01M
	M20x1,5	15,0	36	39,5	4,0	B-RA3N1M
	M25x1,5	15,0	36	39,5	4,0	B-RA3N2M
NPT 1 1/4"	M16x1,5	18,0	45	50	4,0	B-RA4N01M
	M20x1,5	18,0	45	50	4,0	B-RA4N1M
	M25x1,5	18,0	45	50	4,0	B-RA4N2M
	M32x1,5	18,0	45	50	4,0	B-RA4N3M
NPT 1 1/2"	M20x1,5	18,0	55	61	5,0	B-RA5N1M
	M25x1,5	18,0	55	61	5,0	B-RA5N2M
	M32x1,5	18,0	55	61	5,0	B-RA5N3M
	M40x1,5	18,0	55	61	5,0	B-RA5N4M
NPT 2"	M25x1,5	18,0	65	72	5,0	B-RA6N2M
	M32x1,5	18,0	65	72	5,0	B-RA6N3M
	M40x1,5	18,0	65	72	5,0	B-RA6N4M
	M50x1,5	18,0	65	72	5,0	B-RA6N5M
NPT 2 1/2"	M50x1,5	28,0	75	83	6,0	B-RA7N5M
	M60x1,5	28,0	75	83	6,0	B-RA7N60M
	M63x1,5	28,0	75	83	6,0	B-RA7N6M
NPT 3"	M63x1,5	28,0	95	105	8,0	B-RA8N6M
	M70x1,5	28,0	95	105	8,0	B-RA8N70M
	M75x1,5	28,0	95	105	8,0	B-RA8N7M
NPT 3 1/2"	M80x1,5	28,0	110	123	10,0	B-RA9N80M
	M85x1,5	28,0	110	123	10,0	B-RA9N85M
	M90x1,5	28,0	110	123	10,0	B-RA9N8M
NPT 4"	M80x1,5	28,0	120	133,5	10,0	B-RA10N80M
	M85x1,5	28,0	120	133,5	10,0	B-RA10N85M
	M90x1,5	28,0	120	133,5	10,0	B-RA10N8M
	M100x1,5	28,0	120	133,5	10,0	B-RA10N9M